

Name... M/S CHEMIE ..... Admno.....  
 School..... Class.....  
 Index no..... Date.....

232/2  
 PHYSICS  
 Paper 2  
 Theory  
 FORM FOUR  
 2 Hours

**MOMALICHE 3, CYCLE 8 JOINT EXAMS**  
 Kenya Certificate of Secondary Education

**Instructions to candidates**

- a) This paper consists of **TWO** sections : **A** and **B**
- b) Answer **ALL** the questions in section **A** and **B** in the spaces provided
- c) All working **MUST** be clearly shown
- d) Mathematical tables and non-programmable silent electronic calculators may be used.

**For Examiners Use Only**

Section	Question	Maximum score	Candidate's score
A	1-13	25	
B	14.	14	
	15	11	
	16	11	
	17	7	
	18	12	
<b>Total</b>		80	

**SECTION A (25mks)**

1. Figure 1 below shows a plotting compass placed between two strong magnets.  
Fig. 1

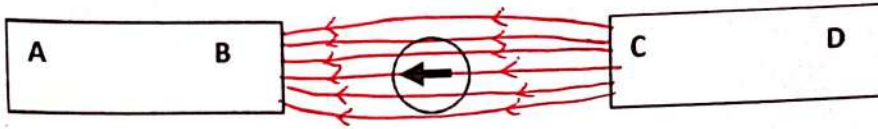

- (I) Give the polarity of the end **D** of the right hand magnet. (1mark)  
.....  
..... *South Pole* .....
- (II) Draw on the diagram the resulting magnetic field pattern between B and C. (2marks)

2. State one property of an image formed by a convex mirror. (1mark)

.....  
..... *- Upright* .....

..... *- Diminished* .....

..... *- Virtual* .....

3. An opaque object is placed before a light source as shown in figure 2 below.

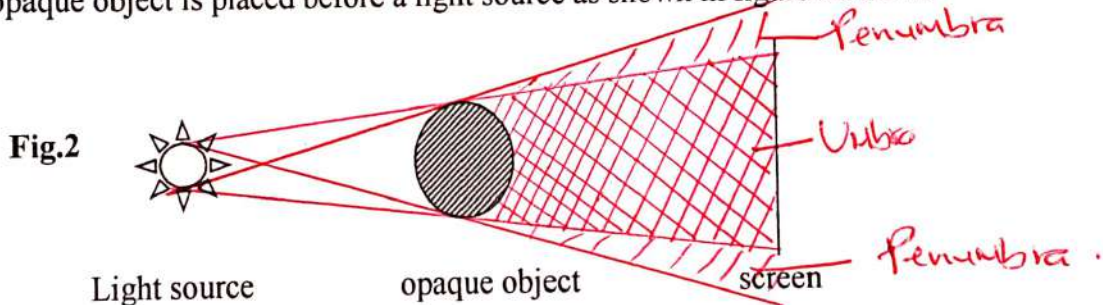

Draw rays in the diagram to show how the shadow is formed. (2marks)

4. In the circuit diagram in figure 3 below, the voltmeter and ammeter read 4v and 40 mA respectively.

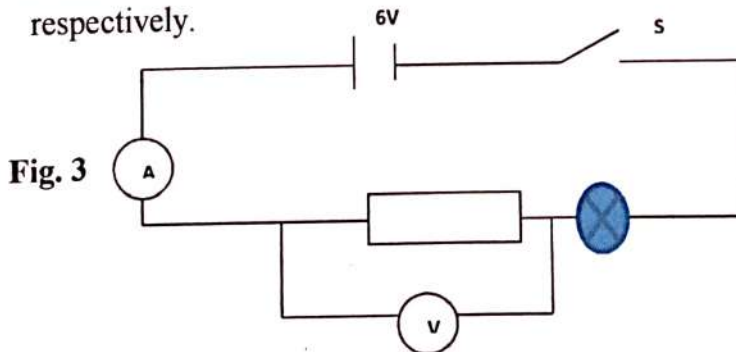

Determine the resistance of the filament of the bulb. (3marks)

*$R_{total} \Rightarrow R = \frac{V}{I} = \frac{6}{0.04} = 150 \Omega$*

Resistance of the resistor =  $\frac{V}{I} = \frac{4}{0.04} = 100 \Omega$

Resistance of filament of the bulb =  $150 - 100 = 50 \Omega$

Alternatively

Voltage across bulb =  $6 - 4 = 2V$

$\therefore R = \frac{V}{I} = \frac{2}{0.04} = 50 \Omega$

5. Name the electromagnetic wave that borders both x-rays and visible light. (1 mark)

Ultra-violet radiation

6. A dry cell is not recharged once used up. However when used well, it can serve someone for some time. State two precautions necessary when using it other than storing it in dry condition.

(2 marks)

- a) Do not draw large current from it.
- b) Do not short circuit its terminals.

7. Give one observable change on water waves when passed from deep to shallow water. (1 mark)

- ✓ Wavelengths Reduces/Decreases
- ✓ Velocity of the wave reduces/Decreases.

8. Figure 4 below shows a conductor in a uniform magnetic field carrying current in the direction shown.

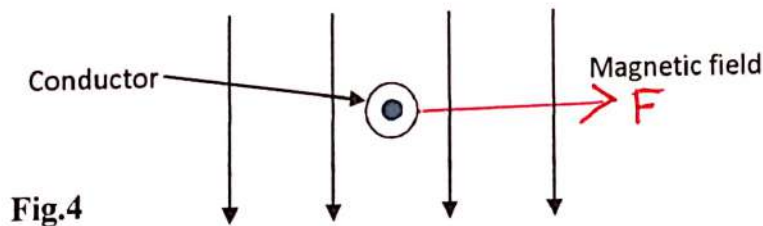

Fig.4

Indicate on the diagram the direction of motion of the conductor.

(1 mark)

9. Name the property of light applied in transmitting light signal in optical fibres.

(1 mark)

Total internal Reflection

10. A heater of resistance  $R_1$  is rated  $P$  watts,  $V$  volts while another of resistance  $R_2$  is rated  $2P$  watts,  $V/2$  volts. Determine  $R_1/R_2$ .

(3 marks)

$$P = \frac{V^2}{R} \Rightarrow R = \frac{V^2}{P} \quad \text{and} \quad R_2 = \left(\frac{V}{2}\right)^2$$

$$\therefore R_1 = \frac{V^2}{P} \quad \therefore \frac{R_1}{R_2} = \frac{V^2}{P} \times \frac{4P}{V^2} = 4$$

11. Figure 5 shows light passing through a transparent block.

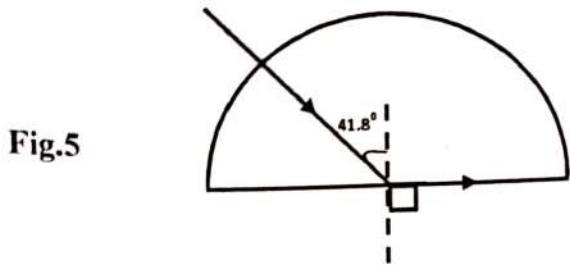

Fig.5

(2 marks)

Determine the refractive index of the block.

$$n = \frac{1}{\sin c} = \frac{1}{\sin 41.8} = \underline{\underline{1.5}}$$

12. What position should a small boy stand in front of a concave mirror to view his;

(i) Enlarged and upright image in a barber shop? (1 mark)

*Between F and the pole.*

(ii) Enlarged and inverted image in a fashion modeling room? (1 mark)

*Between F and C.*

13. Figure 6 below shows a wave profile for a wave whose frequency is 2.5 Hz

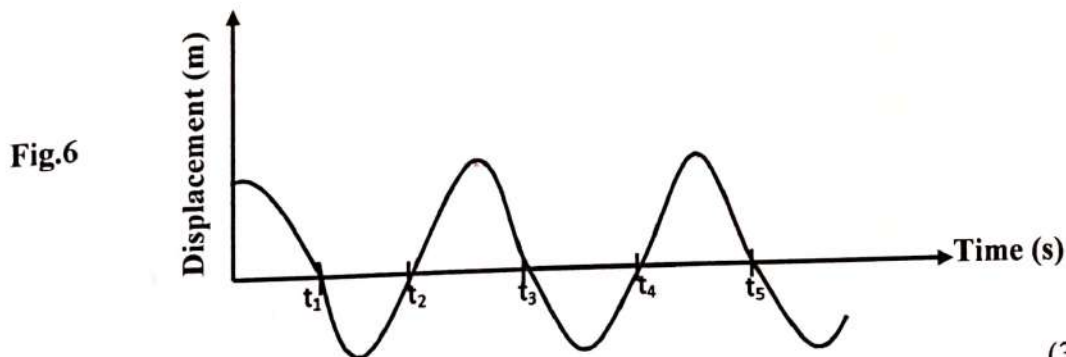

Determine the value of  $t_3$

(3 marks)

$$T = \frac{1}{f} = \frac{1}{2.5} = 0.4 \text{ s}$$

$$\therefore t_3 = \frac{5}{4} \times 0.4 = \underline{\underline{0.5 \text{ Hz}}}$$

**SECTION B (55MKS)**

*Answer all questions in this section the spaces provided*

14. (a) What is dioptries?

(1mark)

A unit for expressing the power of a lens, or mirror, equal to the reciprocal of its focal length in metres.

(b) State two differences between the eye and lens.

(2marks)

Eye	Lens
✓ Variable focal length	✓ Fixed focal length
✓ Constant image distance	✓ Variable image distance
✓ constantly changing pictures	✓ Only one photograph can be taken at a time.

(c). A compound microscope with objective lens  $L_1$  of focal length 0.8cm and an eyepiece lens  $L_2$  of focal length 2.5cm is shown in the figure 7 below. An object  $O$  is placed in front of the objective lens at a distance  $u_1$  of 1.2cm. The system forms a final image  $I_2$  at a distance of 10cm from  $L_2$ . Determine the distance of separation,  $d$ , of lenses  $L_1$  and  $L_2$ . (3marks)

Fig.7

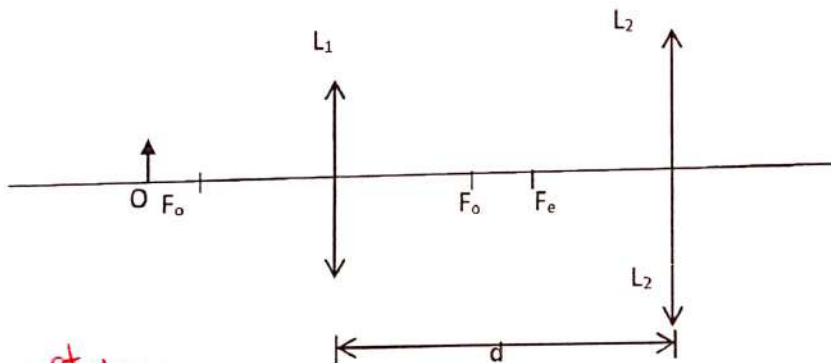

For the 1st image

$$\frac{1}{v} = \frac{1}{f} - \frac{1}{u} = \frac{1}{0.8} - \frac{1}{1.2}$$

$$\therefore v = 2.4 \text{ cm}$$

But  $d = v + u_2$

Hence  $u_2 = d - v$ .

To find  $u_2$  also

$$\frac{1}{u_2} = \frac{1}{f} - \frac{1}{v} = \frac{1}{2.5} - \frac{1}{10}$$

$$u_2 = 3.333 \text{ cm}$$

$$\therefore d = v + u_2$$

$$= 2.4 + 3.333$$

$$= \underline{\underline{5.733 \text{ cm}}}$$

d) The figure 8 below shows an experimental set up consisting of a mounted lens,  $L$ , a screen,  $S$ , a metre rule and a candle.

Fig.8

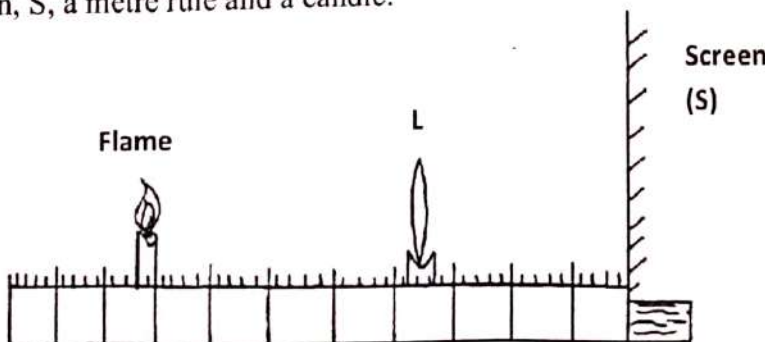

(i) Describe how the set up may be used to determine the focal length  $f$ , of the lens. (4marks)

- ✓ The candle is placed at a distance  $u$ , from the lens; The screen position is adjusted until a sharp image of the flame is obtained ✓
- ✓ The image distance  $v$ , from the lens & screen is measured ✓
- ✓ The process is repeated for other values of  $u$  &  $v$ ; for each set of  $u$ , and  $v$ , focal length  $f$  is found using the formula; ✓

(ii) State why the set up would not work if the lens were replaced with a diverging lens. (1mark)

✓ Diverging lens form virtual images that cannot be formed on the screen.

(iii) An object is placed 20cm from a converging lens of focal length 8cm. Determine how far the image is from the object. (3marks)

$$\frac{1}{f} = \frac{1}{u} + \frac{1}{v}$$

$$\frac{1}{8} = \frac{1}{20} + \frac{1}{v}$$

$$\frac{1}{v} = \frac{1}{8} - \frac{1}{20} = \frac{5-2}{40} = \frac{3}{40}$$

$$v = \frac{40}{3} = 13.33 \text{ cm}$$

$$d = v + u = 13.33 + 20 = 33.33 \text{ cm}$$

15. Figure 9 below shows a pear shaped conductor with positive charge on its surface.

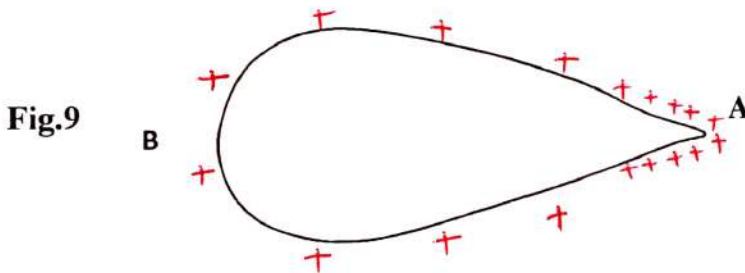

(a) A proof plane is used to touch side **B** of the conductor and then the cap of an uncharged electroscope. This is then repeated with side **A**.

(i). Give the observation made on the electroscope in each case. (2marks)

**B** Deflection is less.

**A** Deflection / Divergence is more.

(ii). What conclusion is drawn from the observation in (i) above. (1mark)

Charges are more concentrated on sharp edges of a conductor.

(b) (i) Draw on the diagram above, the illustration of your conclusion in (ii) above. (1mark)

(ii). Name one application of such a conductor. (1mark)

Discharging of charges from an aircraft's body.

(c). Figure 10 below shows the charged plates of a parallel plate capacitor where the distance of separation,  $d$  is small.

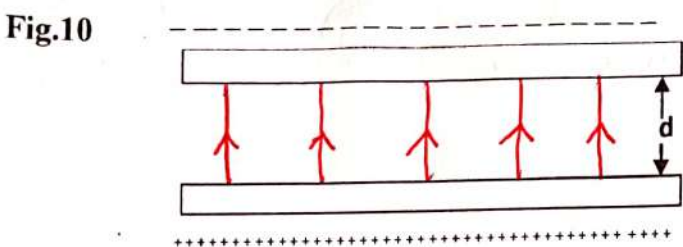

Fig.10

(i). Complete the diagram to show the electric field pattern in the space between the plates.

(1 mark)

(ii). Without changing the distance  $d$  between the plates, suggest one method by which you could increase the capacitance.

(1 mark)

- ✓ Increase the area of overlap.
- ✓ Introduce a dielectric

(iii). State a device where a variable air capacitor could be used.

(1 mark)

Tuning circuits of electronics.

(d). Figure 11 below shows a circuit of three capacitors and a d.c. source.

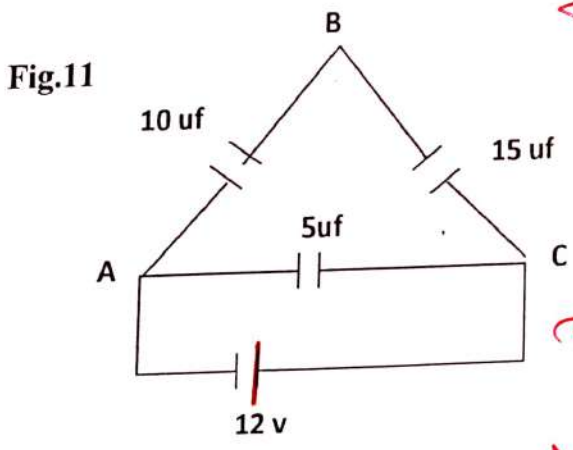

Fig.11

Total capacitance

$$\Rightarrow \left( \frac{10 \times 15}{10 + 15} \right) + 5 = 11 \text{ MF}$$

Total charge  $Q = CV$   
 $Q = 11 \times 12 = 132 \text{ MC}$

Charge on 10 MF & 15 MF will be  $6 \times 12 = 72 \text{ MC}$

Voltage across 10 MF  
 $V = \frac{Q}{C} = \left( \frac{72}{10} \right) \text{ V}$   
 $= 7.2 \text{ V}$

Determine the p.d. across A.B.

(3 marks)

16. Figure 12 below shows the path of a ray of yellow light through a glass prism of refractive index 1.60.

Fig.12

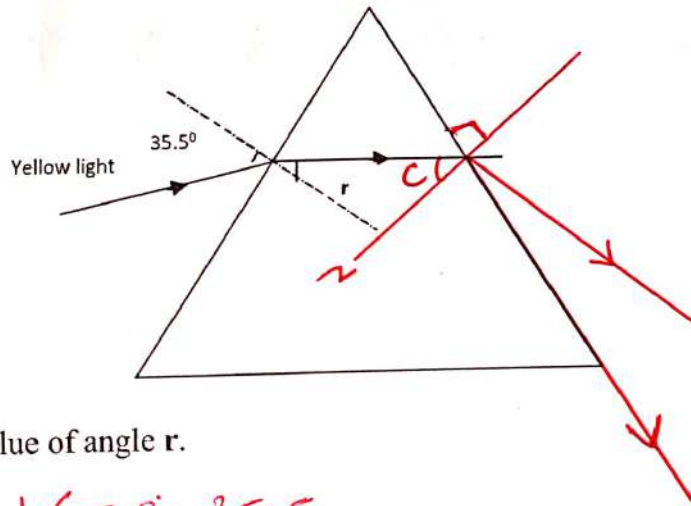

(a). Determine the value of angle  $r$ .

$$n = \frac{\sin i}{\sin r} \Rightarrow 1.6 = \frac{\sin 35.5}{\sin r}$$

$$\sin r = 0.3629$$

$$r = \sin^{-1} 0.3629 = \underline{\underline{21.28^\circ}}$$

(b). Show on the figure the critical angle,  $c$  and determine its value. (3marks)

1 mark for showing  $c$  on the diagram.

$$n = \frac{1}{\sin c}$$

$$c = \sin^{-1} 0.625$$

$$= \underline{\underline{38.68^\circ}}$$

$$\sin c = \frac{1}{1.6} = 0.625$$

(c). Determine the speed of light in glass given that the speed of light in vacuum.

$$(C = 3.0 \times 10^8 \text{ m/s})$$

(3marks)

$$n = \frac{v_1}{v_2} \Rightarrow 1.6 = \frac{3.0 \times 10^8}{v_g}$$

$$v_g = \frac{3.0 \times 10^8}{1.6} = \underline{\underline{1.875 \times 10^8 \text{ m/s}}}$$



- (d). On the same figure, sketch the path of the light after striking the prism if the prism was replaced by another of similar shape but lower refractive index. (Use dotted line for your answer) (2marks)

ON THE DIAGRAM.

17. Figure 13 below shows the circuit of a simple telephone receiver. When a person speaks into the microphone on the other side a varying current flows.

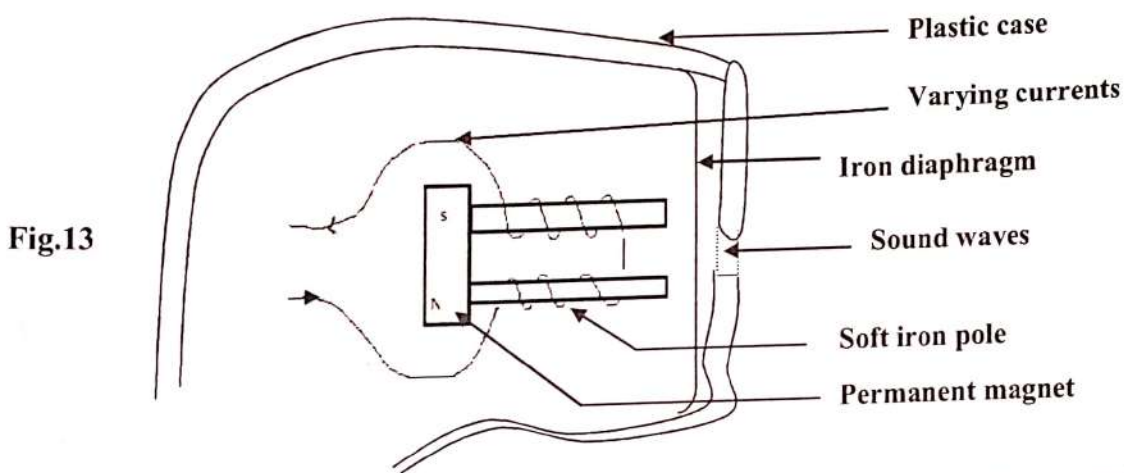

- (i). State the reason why the solenoids are wound in opposite directions around the soft-iron pole pieces as shown. (1mark)

To create opposite polarity of the soft iron cores so as to create magnetic field.

- (ii). Explain how the speech current from the microphone is converted into sound in the receiver. (3marks)

- Varying speech current flowing in the windings of the coil causes a varying magnetic field at the frequency of the speech current.  
 - The varying magnetic field attracts the iron diaphragm which vibrates at the same frequency and reproduces the sound.

(iii). State and explain the effect of replacing the soft iron pole pieces with steel pole pieces.

(3marks)

- ✓ The core becomes a permanent magnet, once magnetised.
- ✓ The core attracts the iron diaphragm once it remains there.
- ✓ It does not vibrate, therefore doesn't reproduce the sound.

18. a) State the Ohms' law.

(1mark)

The current flowing through a conductor is directly proportional to the p.d across its ends provided the temperature and other physical conditions remain constant.

b) Three resistors x, y and z where  $x = 200 \Omega$ ,  $y = 100 \Omega$  and z is unknown resistance are connected in parallel. This arrangement is then placed in a circuit and current passing through, and potential difference across its measured the table below shows the result.

p.d(V)	2.0	4.0	6.0	8.0	10.0	12.0
Current(I) (A)	0.10	0.20	0.30	0.40	0.50	0.60

$$V = IR$$

i) Plot a graph of p.d against current.

(5marks)

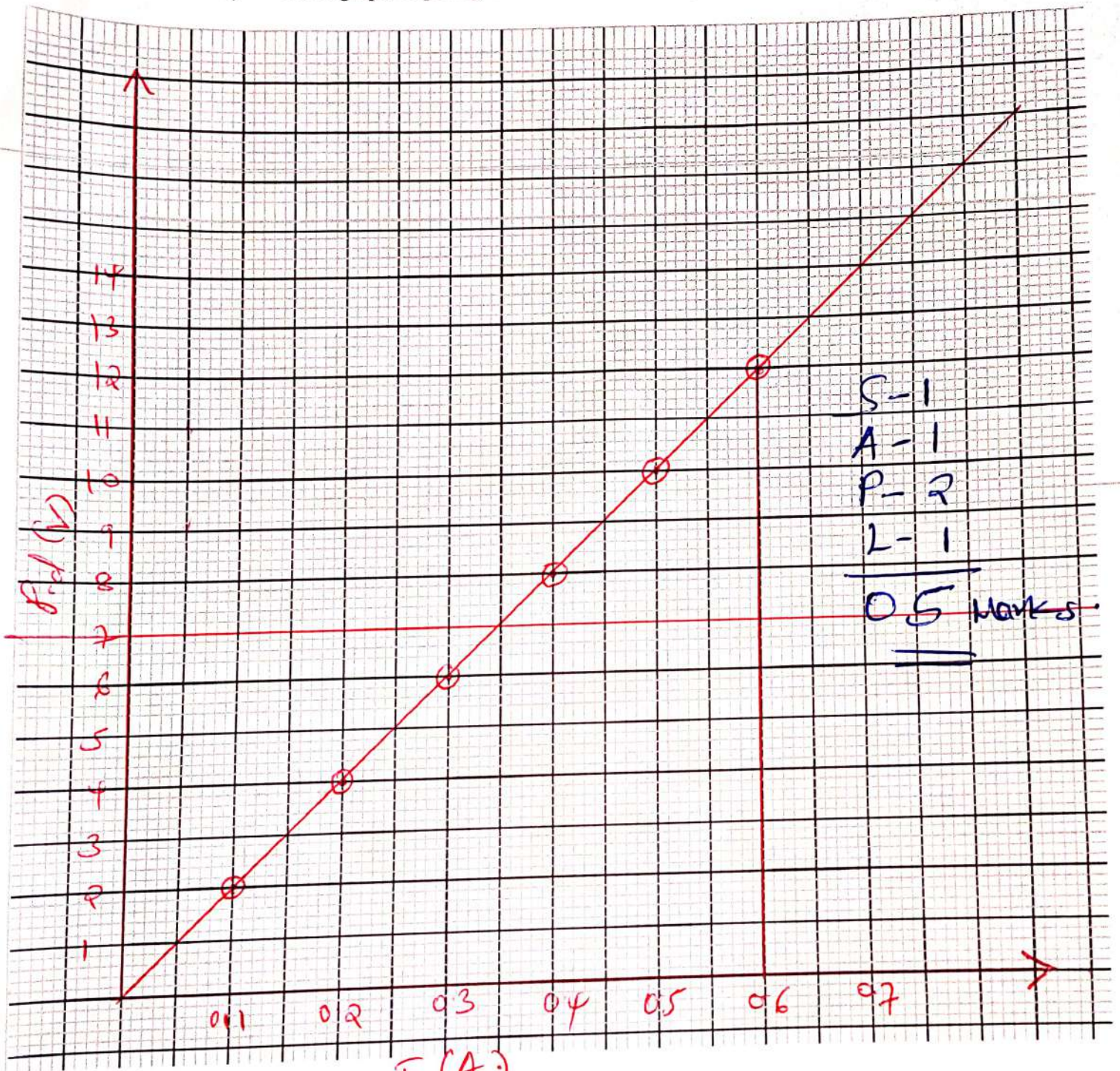

N/B - Axes mark is awarded when correctly labelled with units.

from  $v=IR$  Use your graph to calculate the value of unknown resistance. (3marks)

Slope  $\Rightarrow R = \frac{12-0}{0.6-0} = 20\Omega$

But  $\frac{1}{200} + \frac{1}{100} + \frac{1}{x} = \frac{1}{20}$   $x = \underline{\underline{25\Omega}}$

c) Four resistors are connected in a circuit as shown in the diagram below

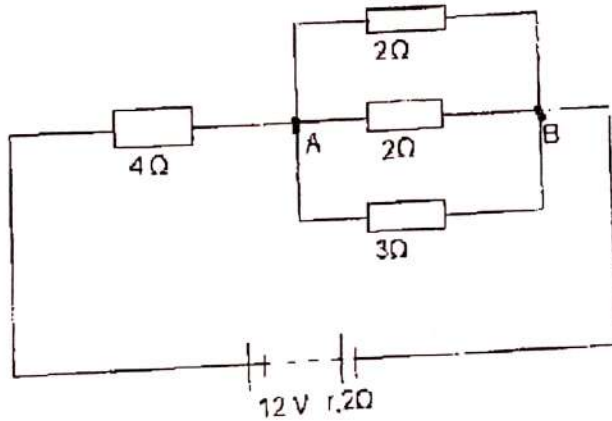

Calculate the p.d across AB. (3marks)

~~$R = \frac{1}{2} + \frac{1}{2} + \frac{1}{3}$~~   
 $R = \frac{4}{3}$   
 $R = \frac{3}{4} = 0.75\Omega$

$R_{\text{series}} = 4 + 0.75 = \underline{\underline{4.75\Omega}}$

$E = I(R+r)$   
 $12 = I(4.75 + 0.2)$

$I = \frac{12}{4.95} = 2.424A$

p.d across  $4\Omega \Rightarrow \frac{4}{4.95} \times 12$   
 $4 \times 2.424 = 9.696V$

$\therefore$  p.d across AB:  
 $= 12 - 9.696$   
 $= \underline{\underline{2.304V}}$